

CORI-FLOW™

Precision Mass Flow Meters / Controllers for
Liquids and Gases



Introduction

Bronkhorst® manufactures precise, compact Mass Flow Meters and Controllers for gases and liquids, based on the Coriolis measuring principle. The instruments are made to customers' specification, suitable for use in laboratory, for integration in manufacturing machines and pilot plants and even for application in industrial or hazardous areas.

CORI-FLOW™ series direct mass flow meters and controllers

Bronkhorst®, specialists in low flow measurement and control, designed the CORI-FLOW™ series mass flow metering instruments to provide high accuracy in two classes: $\pm 0,2\%$ or $\pm 0,5\%$ of Reading.

CORI-FLOW™ utilises an advanced Coriolis type mass flow sensor to achieve unsurpassed performance even with changing operating conditions in pressure, temperature, density, conductivity and viscosity. The instruments are offered as separate flow meters or with close-coupled control valve or pump, thus constituting a compact Coriolis-type mass flow controller. The instruments have analog (0-5 Vdc / 4-20 mA) and RS232 output as standard and can, as options, be equipped with interface to PROFIBUS DP, DeviceNet™, Modbus-RTU or FLOW-BUS.

There are 2 models with overlapping nominal flow ranges from 200 g/h up to 600 kg/h (full scale value), each offering "multi-range" functionality: factory calibrated ranges can be rescaled by the user, maintaining the original accuracy specs. Both meters and controllers are equipped with an IP65 weatherproof housing and are available with ATEX approval for use in Zone 2 hazardous areas.

Fields of application

CORI-FLOW™ instruments are applied in process fluid measurement or control systems in food, (petro-) chemical and pharmaceutical industries, in fermentation installations, in semiconductor processing and in fuel cell technology. Some typical examples of applications are described further on in this brochure.

General CORI-FLOW™ features

- > Direct mass flow measurement
- > Independent of fluid properties
- > Integrated PID controller for control valve or pump
- > Fast response time
- > High accuracy, excellent repeatability
- > Compact, IP65 housing
- > Optional: ATEX approval Cat.3, Zone 2
- > Option: bidirectional measurement

Digital features

- > DeviceNet™, PROFIBUS DP, Modbus-RTU or FLOW-BUS slave
- > RS232 interface
- > Other fieldbus options on request
- > Alarm and (batch) counter functions

CORI-FLOW™ for Liquids and Gases

Measuring principle

The CORI-FLOW™ contains two parallel tube loops, forming part of an oscillating system. When a fluid flows through the tubes, Coriolis forces cause a variable phase shift between the loops, which is detected by sensors and fed into the integrally mounted pc-board. The resulting output signal is strictly proportional to the real mass flow rate.

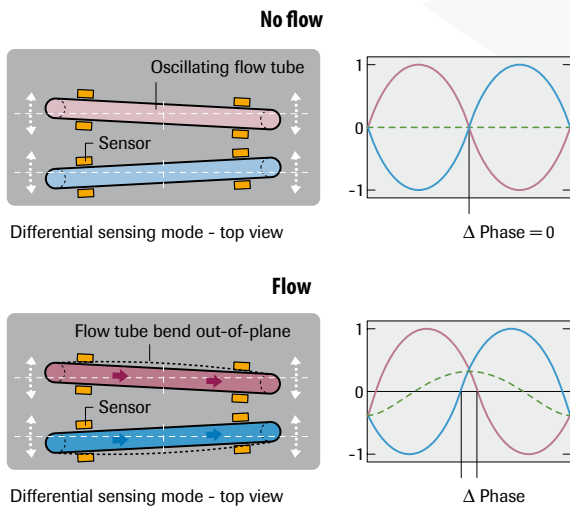

Technical specifications

Performance flow sensor		
Accuracy	Liquid : 0,2% of rate, range 1...100% Gas : 0,5% of rate, range 1...100%	
Flow sensor rates (values in kg/h)		
	M54	M55
Max. flow FS rate	100	600
Min. flow FS rate Liquid	5	20
Min. flow FS rate Gas	10	50
Recommended min. flow	0,2	0,5
Zero stability	< 0,050	< 0,100
Repeatability	: 0,1% of rate (based on digital output)	
Mounting position	: preferred mounting position on liquid service upside down	
Operating limits flow controller		
Control range	: 2...100% (with elastomeric seat)	
Auto shut off	: valve closes when setpoint drops below 1,6%	
Liquids and Gases	: any clean, homogeneous liquid or gas compatible with AISI 316 (or Hastelloy-C22 as an option)	
Differential pressure mass flow controller	: recommended ΔP across control valve at least 50% of total ΔP for liquids and gases.	
Settling time	: approx. 0,5 s	

Mechanical	
Process connections	: std. 1/4" face seal male, 1/4" or 6 mm OD compression type; other on request
Material of construction (wetted parts)	: stainless steel AISI 316L or equivalent; option for M54: Hastelloy-C22
Weight	: meter: approx. 3,1 kg meter + integral valve: 4,4 kg (max.)
Ingress protection	: IP 65 (weatherproof) for meter; for controller on request
Leak integrity	: < 2×10^{-9} mbar l.s ⁻¹ He
Pressure test	: 1,5 times max. stated operating pressure prevailing at customer
Max. operating pressure	: 100 bar
Temperature range (ambient + fluid)	: 0...70°C for standard version, 0...120°C with remote electronics, 130°C ≤ 1 hour allowed for CIP
Electrical	
Power supply	: +15...24 Vdc ± 10%
Consumption electronics	: approx. 80 mA at 15 Vdc
Consumption valve (if present)	: 250 mA (max) at 15 Vdc
Output signal	analog : 0...5 (10) Vdc; 2 kOhm min. load 0 (4)...20 mA (sourcing); 375 Ohm max. load
	digital : PROFIBUS DP, DeviceNet™, FLOW-BUS, RS232, Modbus-RTU
Command signal	analog : 0...5 (10) Vdc; 424 kOhm load 0 (4)...20 mA (sinking); 250 Ohm load
	digital : PROFIBUS DP, DeviceNet™, FLOW-BUS, RS232, Modbus-RTU
Electr. connection	: male, 8-pin Amphenol for power, analog I/O and RS232
	option : standard M12 connector for PROFIBUS DP (female) or DeviceNet™/FLOW-BUS (male)/Modbus (male)
CE approved design	



CORI-FLOW™ Mass Flow Meter with pressure actuated control valve

CORI-FLOW™ mass flow meter/controller

Flow capacity liquid

Basic model	DN (mm)	Nominal Flow*	Capacities (kg/h)																		
			0,5	1,0	2,0	5,0	10	20	50	100	200	500	600								
M54	2	50 kg/h				•	•	•	•	•	•	•	•	•	•	•	•	•	•	•	•
M55	4	500 kg/h																			

* Nominal flow: mass flow rate of liquid at a pressure drop of approx. 1 bar and based on reference conditions of water at approx. 20°C.

Dimensions (mm)

M50 - Series Mass Flow Meter

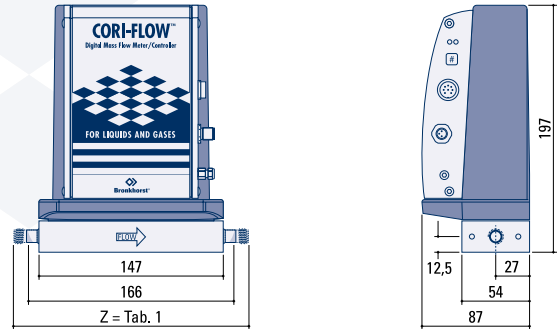

Pressure drop liquid (H₂O)

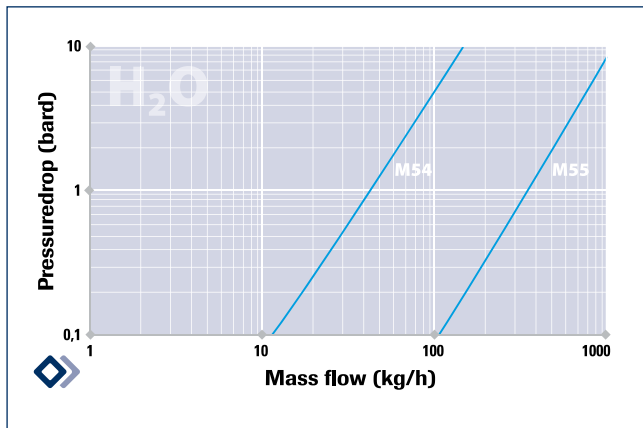

M50C2I - Series Mass Flow Meter Controller

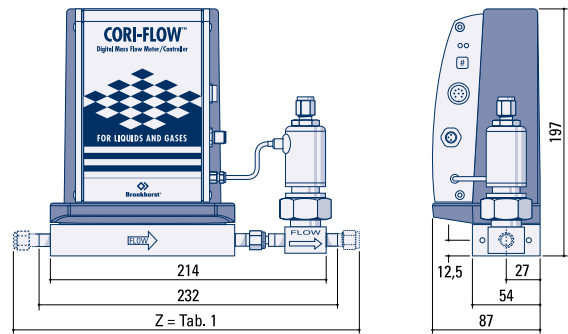

Pressure P₁ vs. mass flow for Air (P₂ = 1 bara)

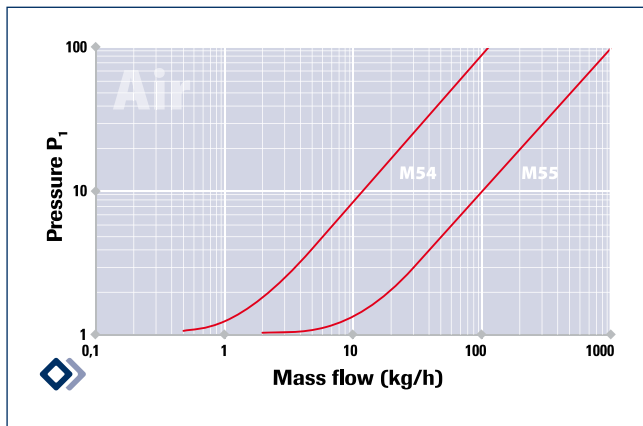

M50 + F-004AI - Series Mass Flow Controller

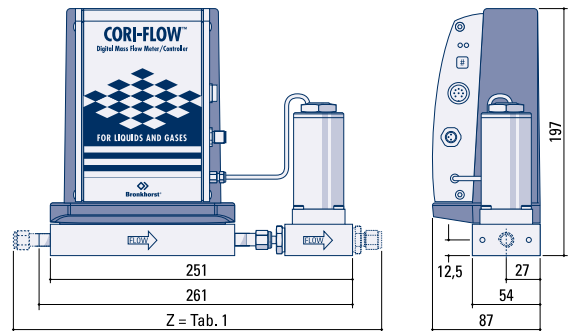

Capacity based on air flow measurement: capacity shown increases with pressure; max. allowable pressure is 100 bara.

Table 1 (Z-values in mm)

Connections (in/out)	M50	M50C2/ M50C5I	M50C4
1/4" compression type	204	270	306
1/4" face seal male	202	267	301
1/4" face seal female	202	267	-
6 mm compression type	204	270	306

M50C5I - Series Mass Flow Controller

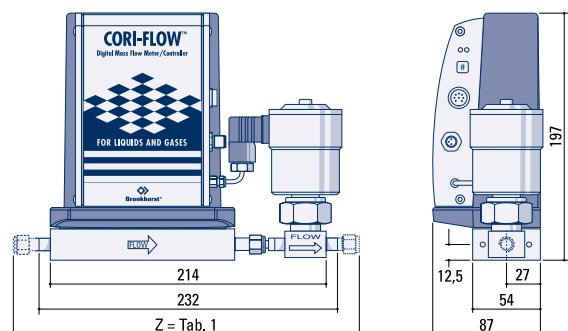

Technical specifications and dimensions subject to change without notice.
Dimensional drawings for other MFCs available on request.

CORI-FLOW™ Applications

Applications

The CORI-FLOW™ is suitable for application in industrial environment, laboratories and OEM installations in the following markets (typically):

- > Surface treatment,
- > Energy (fuel cells),
- > Semiconductor industry,
- > Chemical industry,
- > Pharmaceutical industry,
- > Food industry,
- > Optical fibre industry, etc.

Critical gas measurement

Fluids like carbon dioxide (CO₂) and ethylene (C₂H₄) are difficult to measure when they are in the interphase stage between being a liquid and a gas. This occurs at temperatures >20°C when pressure ranges from approx. 20 bara to approx. 60...95 bara (depending on temperature).

Under these conditions, physical properties like density (ρ) and heat capacity (C_p) change very rapidly which makes an accurate mass flow measurement, based on the thermal principle, very difficult.

CORI-FLOW™ offers a solution here because of the true mass flow measurement, independent of physical properties. The true mass flow of the molecules is measured, regardless of whether the fluid is in gas phase, in liquid phase or indeed somewhere in between. Experiences in the field have proven that this principle of measuring is very accurate and reliable.

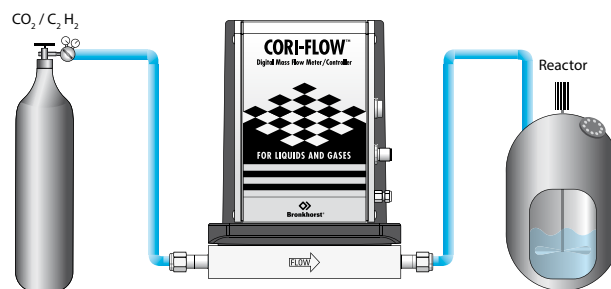

CORI-FLOW™ with pump control, PROFIBUS DP operated

By utilising the integrated PID-control function on the CORI-FLOW™ meter, a desired mass flow can be controlled with either a traditional proportional valve or now, more commonly, with a pump as the actuator. The PID-control to the pump can either be via a direct analogue signal (0...10 V, 0...15 V, 0...20 mA, 4...20 mA) or can be via a voltage/current to frequency converter if this feature is available. The maximum power load for the PID-controller output is ~3.75 Watt. PID-settings for optimal pump control can be set using FlowPlot, a Bronkhorst® tooling program. Most commonly this will be performed in the factory, however, in line with the Bronkhorst® Total Service Concept it is also possible to do this on site.

CORI-FLOW™ instruments can be operated using normal analog signals or via digital interfaces such as RS232 or fieldbus communication. PROFIBUS DP is popular within the process industry as it offers a straight forward connection between a master, a PC or PLC (e.g. Siemens S7-300/400) and its slave devices. Within such a system, the CORI-FLOW™ instrument would act as one of the slave devices and as such would have its control behaviour influenced by the master device. This offers high flexibility in mass flow control.

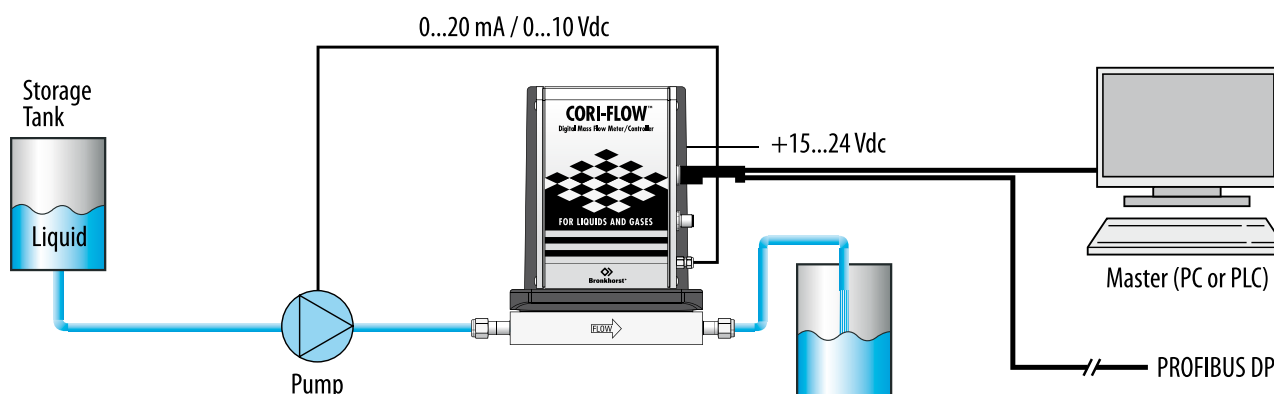

CORI-FLOW™ Applications

CORI-FILL™ Compact Fluid Dosage Assembly

Each Compact Fluid Dosing Assembly consists of a Coriolis Mass Flow Meter of the CORI-FLOW™ or mini CORI-FLOW™ series and a valve or a pump. The onboard PID-controller of the flow meter will be optimized for controlling the valve or the pump and enables an immediate start of dosage after connecting power and fluid accessories. Just enter the desired flow or batch at the operation module (or remotely by computer) and the compact unit will dose true mass flow, for example independent of ambient temperature and back pressure.

Using the integrated CORI-FILL™ technology, the Coriolis meter's totalizer is capable of highly accurate batch dosage. It also ensures the actuator will react as soon as the batch has (almost) been reached.

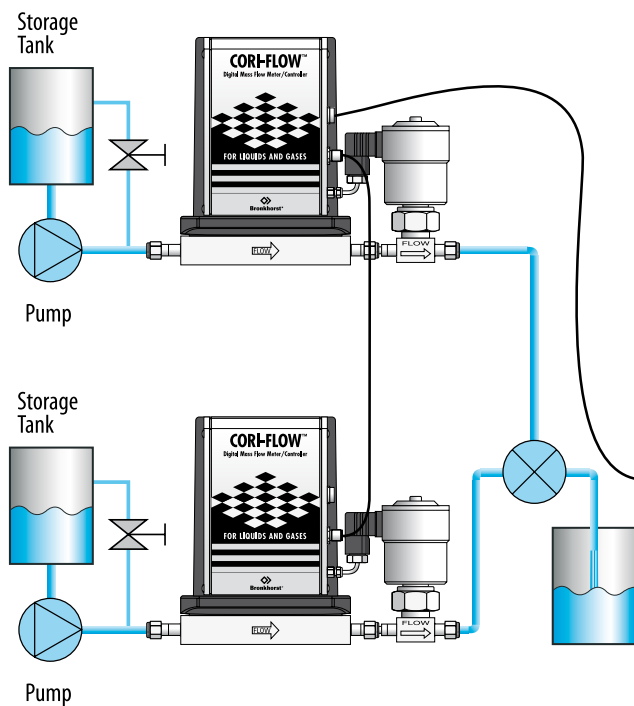

Normally several components would be needed to achieve this:

- > Flowmeter
- > Valve/pump
- > Batchcounting module/PLC
- > Software handling these items
- > Weighing scales

CORI-FILL™ offers all this functionality in one component, in one assembly and from one supplier, without the need of complex programming of additional hardware.

More information about CORI-FILL™ applications can be found at www.cori-fill.com

CORI-FLOW™ instruments can be used to directly control proportional valves, shut-off valves or pumps, using their integrated PID-controller. Thanks to the CORI-FILL™ technology, highly accurate filling applications are possible using the integrated batch-counter.

Using our standard instruments, maximum flow speed is about 1000 kg/h. This enables filling of 278 gram in 1 second or 16,68 kg per minute. For higher or lower flow rates please consult factory.

```

FLOWIDE V4.35 MBO FLOW-BUS HOST
EP: COM1:RS232-MBCFH,mode 3 COM1 38400,n,8,1,- Errors: 0 Mag/sec: 0 Mag 0
22.03.2004 12:13:54 Init Trying to make connection to FLOW-BUS interface
22.03.2004 12:13:56 Init Connection to FLOW-BUS interface OK
22.03.2004 12:14:01 Init Searching for highest occupied node address of FLOW-BUS (ESC to stop)
22.03.2004 12:14:05 Init Highest occupied node address: at FLOW-BUS = 3
22.03.2004 12:14:05 Init Scanning FLOW-BUS to determine system configuration...
22.03.2004 12:14:13 Init Reading FLOW-BUS system configuration OK
22.03.2004 12:14:13 Init Parameter table loaded from database
22.03.2004 12:14:19 Init Database up-to-date, total channels = 1
22.03.2004 12:14:18 Init System configuration overview copied to clipboard
22.03.2004 12:14:18 Init Modules currently connected to FLOW-BUS stored in database
22.03.2004 12:14:19 Init 1 DDE Topics (channel) active
22.03.2004 12:14:19 Init Data acquisition at interface is not possible
22.03.2004 12:14:19 Init Local RS232 FLOW-BUS host interfaces on instrument used
22.03.2004 12:14:19 Init System poll interval = 100 mSec.
22.03.2004 12:14:19 Init System poll channel batch = 10
22.03.2004 12:14:19 Init System real-time poll interval = 25 mSec.
22.03.2004 12:14:19 Init Server is active and ready for any client
    
```

RS232 / FLOW-BUS

DDE

Channel 1
UserTag USERTAG
Serialnr SNM4200000A

Alarm Mode: Off
Counter Mode: Up To Limit

Minimum: 0.0 % Maximum: 80.0 %
Limits: 0 20 40 60 80 100

Delay time: 3 sec

Alarm Setpoint Mode: Setpoint Change
Counter Setpoint Mode: Setpoint Change

Limit: 500 g

Reset Flowbus
Reset Flow/Keyb/Ext

Buttons: Reset Alarm, Reset Counter, Apply, OK, Cancel

UserTag USERTAG
Serialnr SNM4200000A

Channel 1
Setpoint 100.0 % Measure 100.0 %

45.00 kg/h

269.50 g

Buttons: Advanced, New, About, Quit

Node 3 Type CORIFC
Model MS4CSI
Cust.Model STANDARD
Device Funct. Controller

Setpoint/Control Mode: BUS/RS232

Node 4 Factor 100.00 %
Setpoint slope 0 x 0.1 s
Capacity 100% = 45.00 kg/h

Fluid 1 H2O
Sensortype Liquid/gas mass (controller)

Buttons: Alarm&Counter, Alarm Info

Channel 1
UserTag USERTAG
Serialnr SNM4200000A

Alarm Mode: Off
Counter Mode: Up To Limit

- Error message
- Warning message
- Minimum alarm
- Maximum alarm
- Counter limit reached
- Response/Pwr-up alarm
- Master/slave alarm
- Hardware Error

Counter: 5.0000E+2 g

Buttons: Reset Alarm, Reset Counter, Close

Model number identification MFM and MFC

M5N - AN(I) - A A A - NN - A - A

Mass flow meter

M54	Nominal range	50 kg/h
M55	Nominal range	500 kg/h

Control valve

C0 (I)	Low Flow control valve (nc) PN100	gas; Kv-max = $6,6 \times 10^{-2}$
C1 (I)	Low Flow control valve (no) PN100	gas; Kv-max = $6,6 \times 10^{-2}$
C2 (I)	Low Flow control valve + purge connection (nc) PN100	liquid; Kv-max = $2,3 \times 10^{-3}$
F-004AI	Medium Flow control valve (nc) PN10	gas or liquid; Kv-max = $3,0 \times 10^{-1}$
CS1	Medium Flow control valve (nc) PN100, IP65	gas or liquid; Kv-max = $6,6 \times 10^{-2}$

add 'I' for IP65 coil on control valve

PC-board

A	with RS232 and analog I/O	(nc)	controller-function
B	with RS232 and analog I/O	(no)	controller-function
D	with RS232 and DeviceNet I/O	(nc)	controller-function
E	with RS232 and DeviceNet I/O	(no)	controller-function
M	with RS232 and Modbus I/O	(nc)	controller-function
N	with RS232 and Modbus I/O	(no)	controller-function
P	with RS232 and PROFIBUS DP I/O	(nc)	controller-function
Q	with RS232 and PROFIBUS DP I/O	(no)	controller-function
R	with RS232 and FLOW-BUS I/O	(nc)	controller-function
S	with RS232 and FLOW-BUS I/O	(no)	controller-function

Output

A	0...5V
B	0...10V
F	0...20 mA sourcing
G	4...20 mA sourcing

Supply voltage

D	+ 15...24 Vdc
---	---------------

Connections (in/out)

2	1/4"	OD compression type
3	6 mm	OD compression type
4	12 mm	OD compression type
5	1/2"	OD compression type
7	1/4"	Face seal female
8	1/4"	Face seal male
9	Other	

Internal seals

0	None (sensors)
V	Viton® (valves for gas)
E	EPDM
K	Kalrez®-6375

Material

S	Stainless steel
H	Hastelloy-C22



Authorised Distributor



Managing Technology & Services

MTS ENGINEERS PVT. LTD.

B/408, Wall Street-II, Opp. Orient Club, Near Gujarat College,
Ellisbridge, Ahmedabad-380 006, Gujarat, INDIA.
T. +91 79 2640 0063 / 3016 0063 • F. +91 79 4004 7430
www.mtsengrs.com



Bronkhorst High-Tech B.V. Nijverheidsstraat 1a, NL-7261 AK Ruurlo The Netherlands
T +31(0)573 45 88 00 F +31(0)573 45 88 08 I www.bronkhorst.com E info@bronkhorst.com



9.60.032C
©BHT1512-111