

# Compact Dosing System

Accurate Liquid Dosage with Mass Flow Meter Controlled Pumps

## Introduction

Bronkhorst Cori-Tech B.V. manufactures Coriolis Mass Flow Meters and Controllers for gases and liquids. The **CORI-FLOW**® product range offers true mass flow in a range from 20 g/h up to 600 kg/h. The compact **mini CORI-FLOW**® Series are designed for capacities from 200 mg/h up to 30 kg/h. Both **mini CORI-FLOW**® and **CORI-FLOW**® instruments can be combined with a micro annular gear pump, constituting a simple and compact liquid dosing system. Up to 20 kg/h, such a combination of flowmeter and pump can be integrated in a compact portable housing with local operation and power supply, to provide a highly accurate and stable liquid mass flow dosage unit.

## Compact Liquid Dosing Systems

Each Compact Liquid Dosing System consists of a Mass Flow Meter of the **mini CORI-FLOW**® series, a gear pump, an operation module and power supply. The onboard PID-controller of the flow meter will be optimized for control of the gear pump and enables an immediate start of dosage after connecting power cable and fluid accessories. Just enter the desired flow at the operation module (or remotely by computer) and the compact unit will dose true mass flow, independent of e.g. ambient temperature and back pressure. Several models are available to cover wide flow control and pressure ranges, also for aggressive fluids.

## Features

- > Complete modular, small sized, liquid dosing system, ideal for laboratory use or system integration
- > Gear pump directly controlled by mass flow meter with adjustable PID-controller via voltage output signal
- > Direct liquid true mass flow dosage (not volumetric)



Dosing unit for flowranges up to 4000 g/h, max. 5 barg (based on water @ 1 bara, 20 °C)

- > High accuracy and stability (nearly pulse-free)
- > No balance required
- > Flow rate independent of back (process) pressure and temperature
- > No need to pressurize liquid source
- > Prevents gas bubbles in dosed liquid
- > Flow meter controlled pump provides long term accuracy
- > Integrated pump protected from running dry
- > Indication of:
  - measured value (direct or %) and setpoint
  - totalized flow; optional batch control and alarm functions
  - pressure (optional)
- > Desired flow to be set through:
  - Keyboard on operation module,
  - Analog 0...5(10) V / 0(4)...20 mA or
  - Digital communication by:  
RS232, Profibus-DP®, DeviceNet™,  
Modbus-RTU, LonWorks or FLOW-BUS

# Compact Liquid Dosing System

## Alternative for HPLC pump with balance

Traditionally, dosage of mass flow is achieved by using a (HPLC) metering pump with a balance. The pump offers volumetric flow and the balance is used to measure the amount of liquid mass pumped in or out of a cup. Bronkhorst Cori-Tech dosing units, however, offer continuous true mass flow and make the use of balances superfluous. This ideal combination enables savings in time, (raw fluid) material and equipment.

## Specifications

- Flow ranges: 10 g/h...20 kg/h FS (several models)
- Accuracy of mass flow sensor:  $\pm 0,2\%$  of rate
- Pressure range: 1.5...80 bard max (depending on pump type and fluid dynamic viscosity)
- Temperature: 0...50 °C
- Fluid connections:  $1/8$ " OD compression type (other on request)
- Electrical connections: sub-D9 for RS232 (for operation and configuration)
- Local operation via E-7000-13 R/C-panel
- Power: 110 Vac / 230 Vac
- Housing:  $1/2$  19" table top, with carrying handle

## Options

- A pressure meter or controller can be added to the system to monitor and/or control/limit the pressure at the outlet.
- Wetted parts in Hastelloy-C for flow meters and pumps (also inert pumps available in ceramic coated versions).

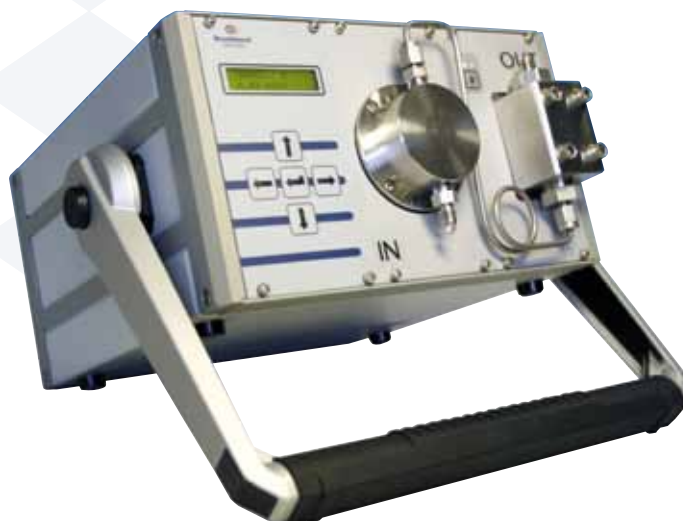

Dosing unit for flowranges up to 20 kg/h. max. 40 bard (based on water @ 1 bara, 20 °C)



Unit with mini CORI-FLOW® gear pump and optional pressure sensor

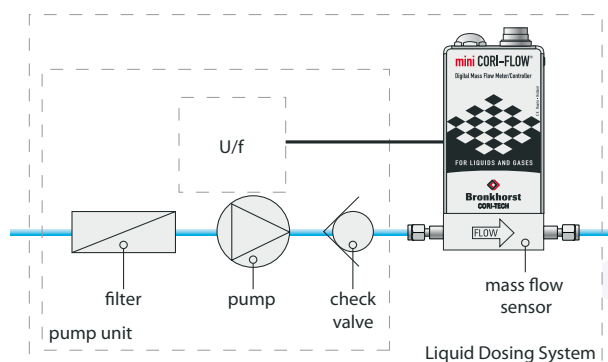

## Bronkhorst Cori-Tech B.V.

Nijverheidsstraat 2-6  
7261AK Ruurlo The Netherlands  
Tel. +31 573 458890 Fax. +31 842 292375  
Email: [info@bronkhorst-cori-tech.com](mailto:info@bronkhorst-cori-tech.com)  
Internet: [www.bronkhorst-cori-tech.com](http://www.bronkhorst-cori-tech.com)



## Authorised Distributor



Managing Technology & Services

MTS ENGINEERS PVT. LTD.

B/408, Wall Street-II, Opp. Orient Club, Near Gujarat College,  
Ellisbridge, Ahmedabad-380 006, Gujarat, INDIA.  
T: +91 79 2640 0065 / 3016 0063 • F: +91 79 4004 7430  
[www.mtsengrs.com](http://www.mtsengrs.com)

